



REFERENCE:
L0077S

COUNTRY OF ORIGIN: PRC

WARNINGS FOR THE USER:

Warning!

-Do not look directly into the light - it may cause damage or even loss of vision.

-Install only in specialized workshops or professional services.

- Use in open space only.

- Use in accordance to the purpose.



www.truck-kamar.pl

LED WORK LAMP 9X LED SQUARE SPOT

PHOTO AND TECHNICAL DRAWING:

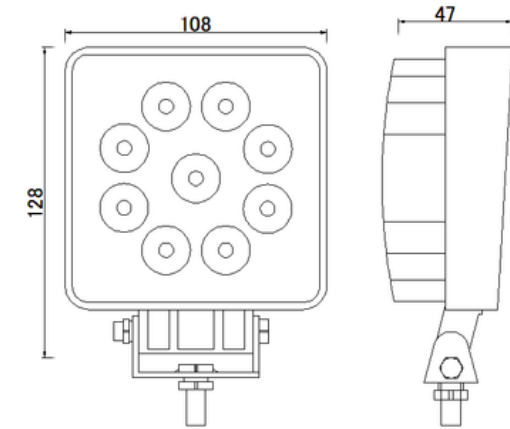

TECHNICAL SPECIFICATIONS:

MATERIAL	LED/LM QUANTITY	MOUNTING	CABLE	FUNCTION	WATT	VOLTAGE	CERTIFICATES	PACKING/WEIGHT
» Lens: PS » Housing: AL	» 9 » 1430 LM	» screw	» 300mm	» work light » spot	» 24W	» 12V/24V	» ECE R10	» cart. dim.: 119x65x148 mm » lamp weight: 317g » 20 pcs/bulk box

INSTALLATION INSTRUCTIONS:

LED work lamp used to illuminate the working area in vehicles off the public roads. For proper installation and use of lights it is advisable to read the instructions to ensure personal safety and durability of the products. The device must be installed out of reach of children. The appliance must be fitted out of reach of children. If you would like to change the existing incandescent/halogen lighting on LED lighting - installation does not require to make any changes, except replacing the lamps. While installing new / additional LED lighting you must verify the current capacity of the switch to which you are going to connect the lamp. If you exceed the current carrying capacity of the switch to which you want to connect LED lighting, use an additional relay - the installation of lamps should make a professional engineer. Use in airy places. The installation should be made by professional workshop of specialized service. User's manual available for download at www.truck-kamar.pl. Lamps must be installed only in accordance with UNECE regulations

We reserve the right to change technical data and any errors. Photos and specifications are for reference only, and the actual product may vary slightly. Reproduction in whole or parts of the catalog without written authorization is prohibited.